

MAX PANEL SUPPLY PROTECTIVE DEVICE RATING:
400 AMPS

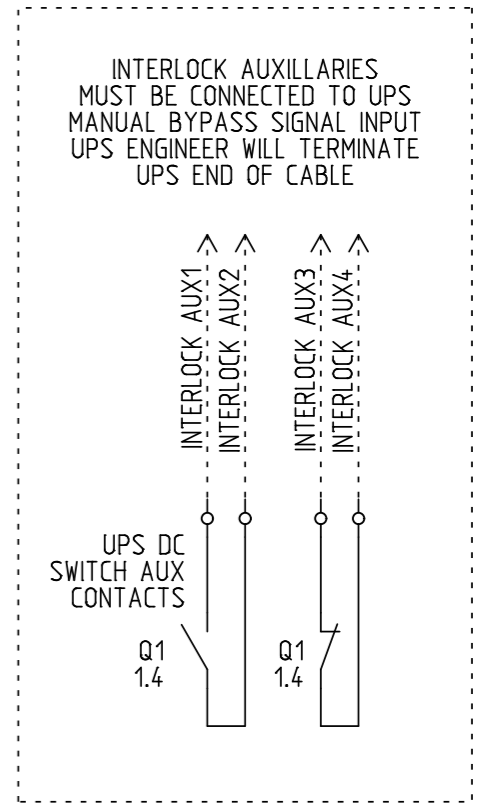
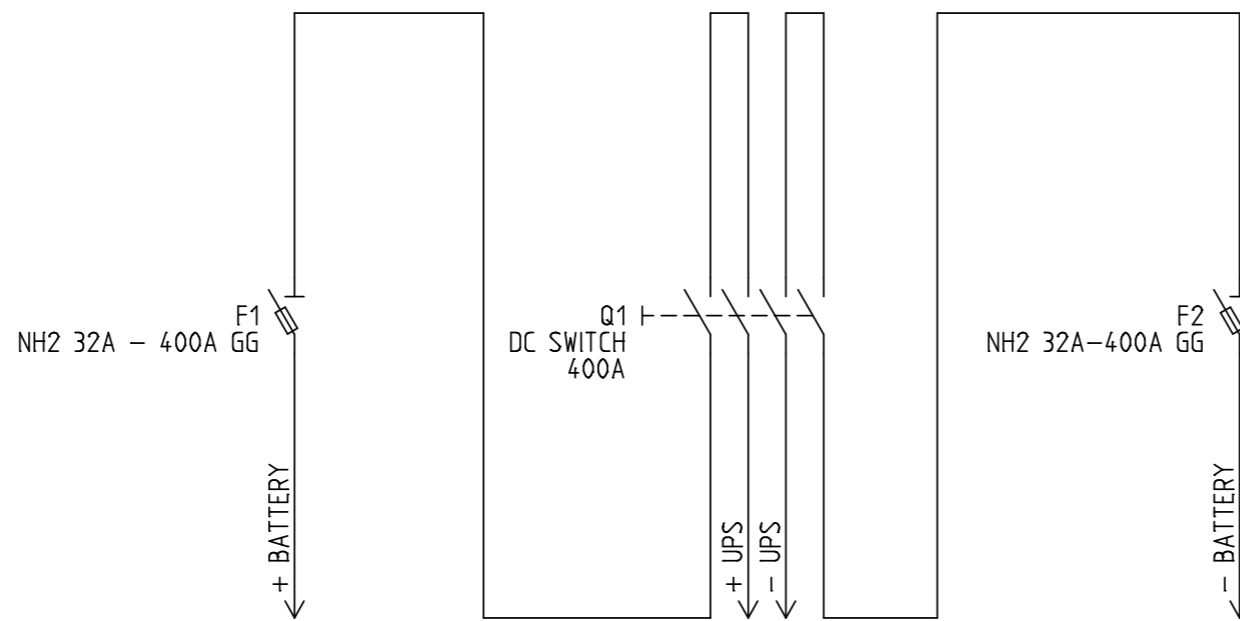

FUSE RATING OPTIONS:

32A
 63A
 100A
 125A
 160A
 200A
 250A
 315A
 400A

PLEASE SPECIFY ON ORDER

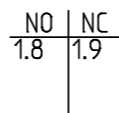

- NOTES:**
- 1) PRODUCT MUST BE INSTALLED IN COMPLIANCE WITH ALL NATIONAL AND LOCAL ELECTRICAL REGULATIONS
 - 2) PLEASE REFER TO UPS PRODUCT MANUALS FOR ADDITIONAL INFORMATION
 - 3) ALL DIMENSIONS IN MM UNLESS OTHERWISE SPECIFIED
 - 4) 4 - CORE SHIELDED SIGNAL CABLE MUST BE RUN FROM EMBS TO EACH UPS UNIT
 - 5) ALL DASHED LINES EXTERNAL TO BYPASS PANEL

PRODUCT REF:	RB1-DC-ISO-400-3P-1S	REV NO:	1
DOCUMENT NUMBER:	RBECAD00200	CREATION DATE:	29/04/2016
PAGE DESCRIPTION:	MAIN SWITCH'S	REV DATE:	03/04/2018
PROJECT NO:	SUBMITTAL DRAWING	DRAWN BY:	R BARNES
PAGE TEMPLATE REF:	RBQS00075REV2	CHECKED BY:	M BRADLEY
PRODUCT WEIGHT:	35KG	SHEET NUMBER:	1 OF 2

TOP VIEW:

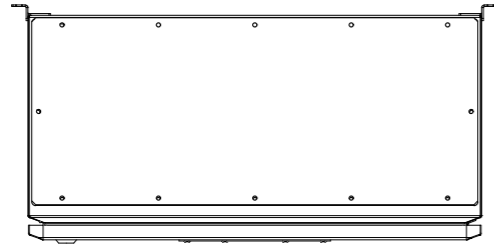

MECHANICAL LAYOUT

ISO VIEW:

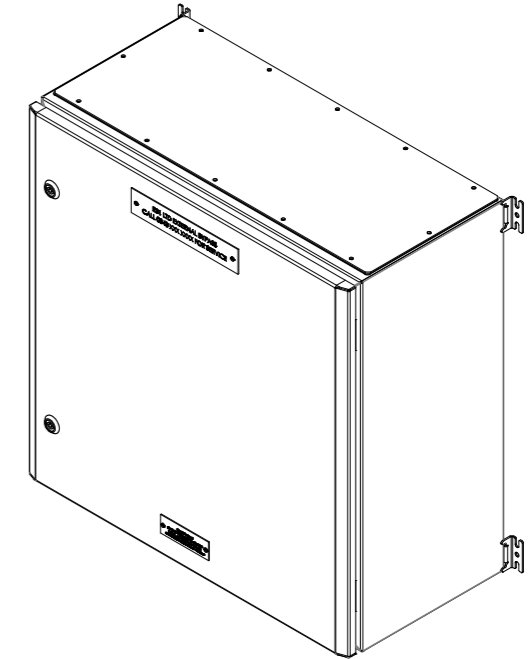

LEFT VIEW:

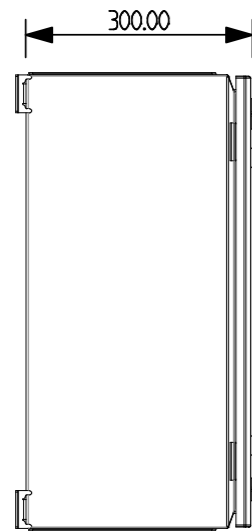

FRONT VIEW:

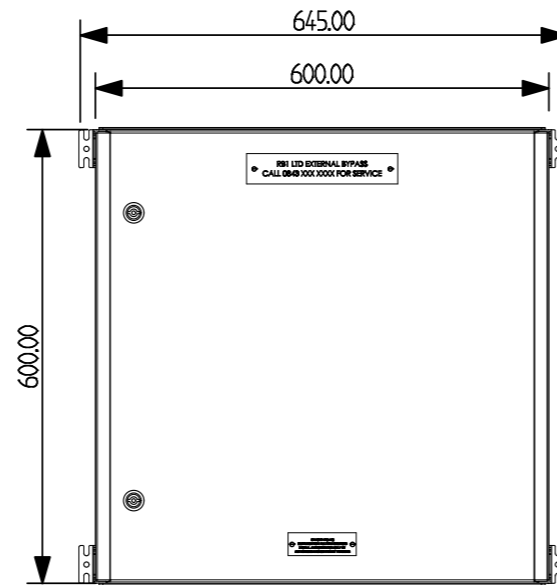

BOTTOM VIEW:

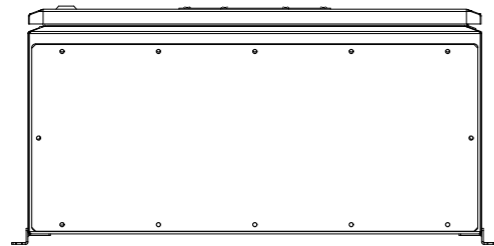

CABLE GLANDING:

MAIN DC FEED: TOP/BOTTOM
BATTERY FEEDS: TOP/BOTTOM

CABLE TERMINATIONS:

MAIN DC FEED: 1 x M10 BOLT OR 2 x M8 BOLT
BATTERY CONNECTIONS: M10 BOLT
EARTH: M6/M8 BOLT

NOTES:

- 1) PRODUCT MUST BE INSTALLED IN COMPLIANCE WITH ALL NATIONAL AND LOCAL ELECTRICAL REGULATIONS
- 2) PLEASE REFER TO UPS PRODUCT MANUALS FOR ADDITIONAL INFORMATION
- 3) ALL DIMENSIONS IN MM UNLESS OTHERWISE SPECIFIED
- 4) 4 - CORE SHIELDED SIGNAL CABLE MUST BE RUN FROM EMBS TO EACH UPS UNIT
- 5) ALL DASHED LINES EXTERNAL TO BYPASS PANEL

PRODUCT REF:	RB1-DC-ISO-400-3P-1S	REV NO:	1
DOCUMENT NUMBER:	RBECAD00200	CREATION DATE:	29/04/2016
PAGE DESCRIPTION:	MECHANICAL LAYOUT	REV DATE:	13/03/2017
PROJECT NO:	SUBMITTAL DRAWING	DRAWN BY:	R BARNES
PAGE TEMPLATE REF:	RBQS00078REV2	CHECKED BY:	M BRADLEY
PRODUCT WEIGHT:	35KG	SHEET NUMBER:	2 OF 2