

MAX PANEL SUPPLY PROTECTIVE DEVICE RATING:
80 AMPS

EARTH

EARTH 25

NO	NC
1.8	1.9

NOTES:

- 1) PRODUCT MUST BE INSTALLED IN COMPLIANCE WITH ALL NATIONAL AND LOCAL ELECTRICAL REGULATIONS
- 2) PLEASE REFER TO UPS PRODUCT MANUALS FOR ADDITIONAL INFORMATION
- 3) ALL DIMENSIONS IN MM UNLESS OTHERWISE SPECIFIED
- 4) 4 - CORE SHIELDED SIGNAL CABLE MUST BE RUN FROM EMBS TO EACH UPS UNIT
- 5) ALL DASHED LINES EXTERNAL TO BYPASS PANEL

PRODUCT REF:	RB1-C-EMBS-80A-2P-ISO	REV NO:	1
DOCUMENT NUMBER:	RBECAD-00079	CREATION DATE:	29/04/2016
PAGE DESCRIPTION:	MAIN SWITCH'S	REV DATE:	25/05/2016
PROJECT NO:	SUBMITTAL DRAWING	DRAWN BY:	R BARNES
PAGE TEMPLATE REF:	RBQS00075REV2	CHECKED BY:	M BRADLEY
PRODUCT WEIGHT:	15KG	SHEET NUMBER:	1 OF 5

EXAMPLE UPS UNIT CONNECTION DIAGRAM FOR ILLUSTRATION ONLY
 CHECK WITH UPS UNIT SUPPLIER FOR EXACT CONNECTION
 CONFIGURATION FOR THE AC, DC AND AUXILLARY CONNECTIONS

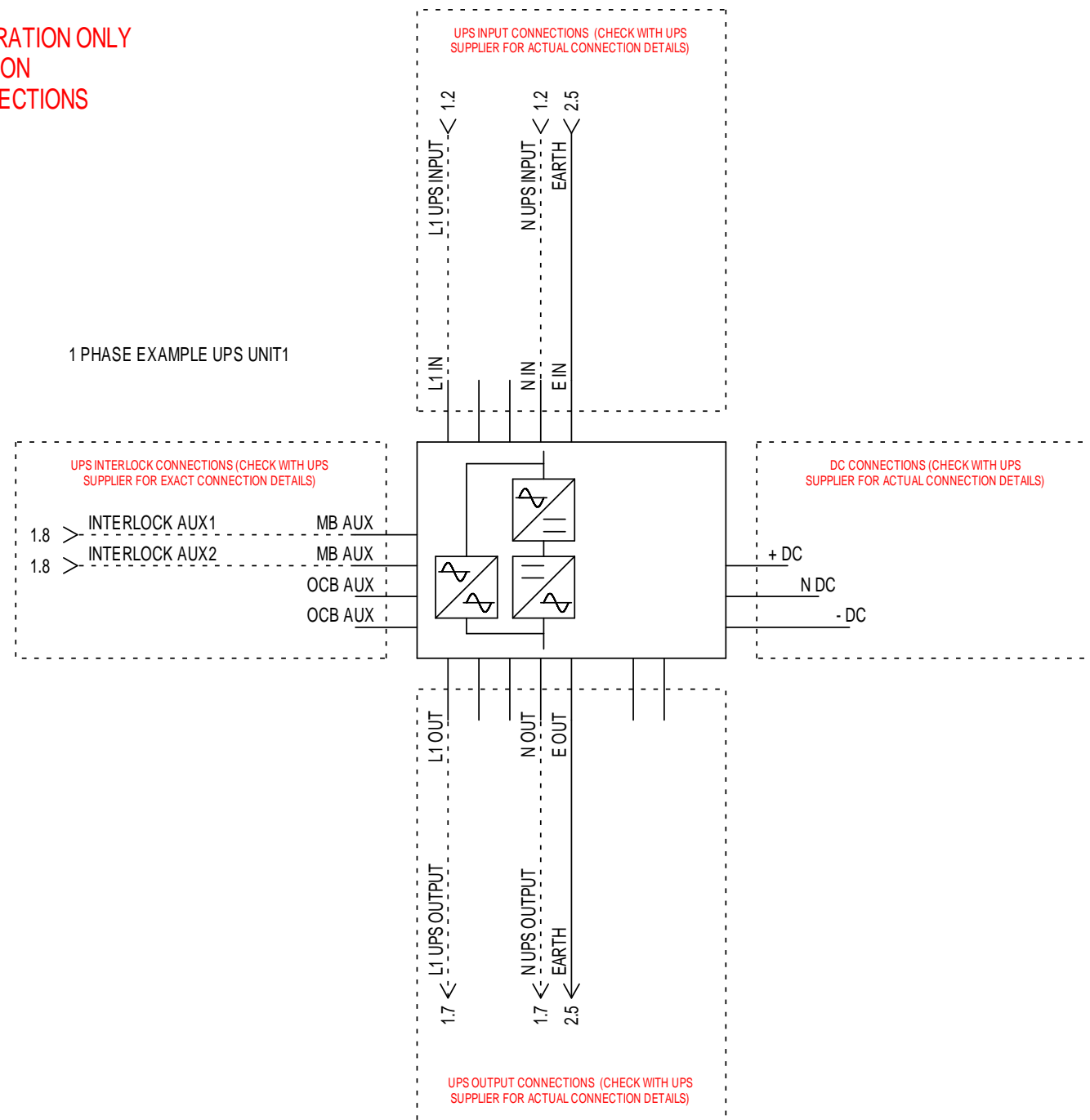

NOTES:

- 1) PRODUCT MUST BE INSTALLED IN COMPLIANCE WITH ALL NATIONAL AND LOCAL ELECTRICAL REGULATIONS
- 2) PLEASE REFER TO UPS PRODUCT MANUALS FOR ADDITIONAL INFORMATION
- 3) ALL DIMENSIONS IN MM UNLESS OTHERWISE SPECIFIED
- 4) 4 - CORE SHIELDED SIGNAL CABLE MUST BE RUN FROM EMBS TO EACH UPS UNIT
- 5) ALL DASHED LINES EXTERNAL TO BYPASS PANEL

PRODUCT REF:	RB1-C-EMBS-80A-2P-ISO	REV NO:	1
DOCUMENT NUMBER:	RBECAD-00079	CREATION DATE:	12/05/2016
PAGE DESCRIPTION:	UPS UNIT	REV DATE:	25/05/2016
PROJECT NO:	SUBMITTAL DRAWING	DRAWN BY:	R BARNES
PAGE TEMPLATE REF:	RBQS00078REV2	CHECKED BY:	M BRADLEY
PRODUCT WEIGHT:	15KG	SHEET NUMBER:	2 OF 5

DO NOT USE THIS PROCEDURE IF THE MAINS IS NOT AVAILABLE. IF IN ANY DOUBT CONTACT YOUR UPS SERVICE PROVIDER.

STEP A (NORMAL POSITION)

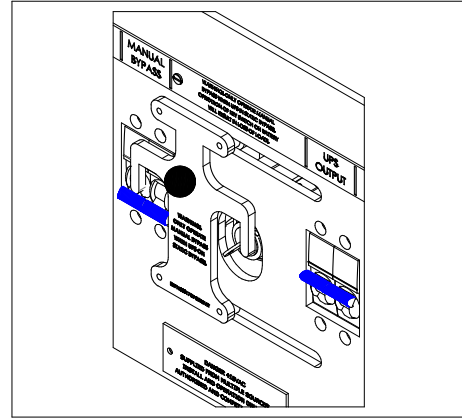

MANUAL BYPASS:
-IN THE OFF POSITION

INTERLOCK KEY :
-INSERTED + TURNED CLOCKWISE

UPS OUTPUT:
-IN THE ON POSITION

UPS UNIT:
-ONLINE - LOAD ON UPS

STEP B

REFER TO UPS USER MANUAL TO SWITCH THE UPS UNIT (OR UNITS) TO STATIC BYPASS

ONCE UPS UNIT (OR UNITS) ARE IN STATIC BYPASS CONTINUE THE SWITCHING SEQUENCE

MANUAL BYPASS:
-IN THE OFF POSITION

INTERLOCK KEY :
-INSERTED + TURNED CLOCKWISE

UPS OUTPUT:
-IN THE ON POSITION

UPS UNIT:
-STATIC BYPASS - LOAD ON MAINS

STEP C

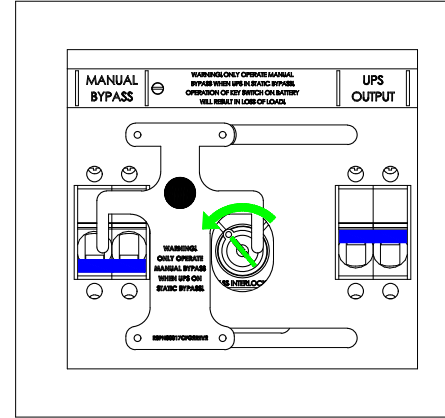

MANUAL BYPASS:
-IN THE OFF POSITION

INTERLOCK KEY :
-INSERTED + TURNED ANTI-CLOCKWISE

UPS OUTPUT:
-IN THE ON POSITION

UPS UNIT:
-STATIC BYPASS - LOAD ON MAINS

STEP D

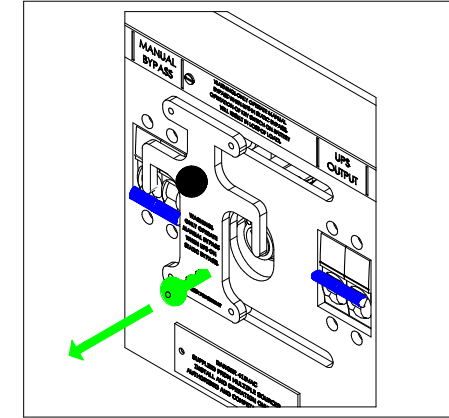

MANUAL BYPASS:
-IN THE OFF POSITION

INTERLOCK KEY :
-REMOVED

UPS OUTPUT:
-IN THE ON POSITION

UPS UNIT:
-STATIC BYPASS - LOAD ON MAINS

STEP E

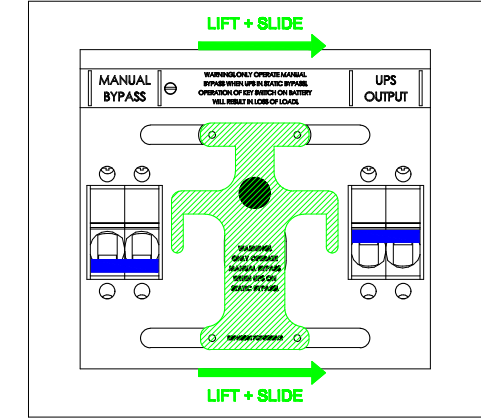

MANUAL BYPASS:
-IN THE OFF POSITION

INTERLOCK KEY :
-REMOVED

UPS OUTPUT:
-IN THE ON POSITION

UPS UNIT:
-STATIC BYPASS - LOAD ON MAINS

STEP F

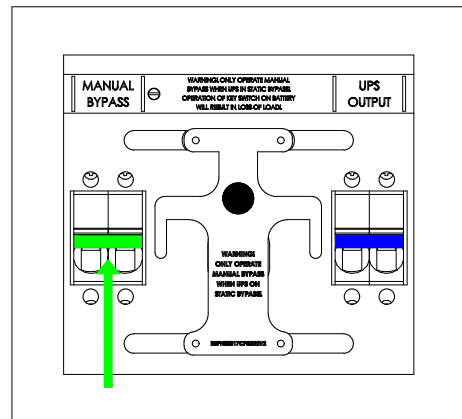

MANUAL BYPASS:
-IN THE ON POSITION

INTERLOCK KEY :
-REMOVED

UPS OUTPUT:
-IN THE ON POSITION

UPS UNIT:
-STATIC BYPASS - LOAD ON MAINS

STEP G

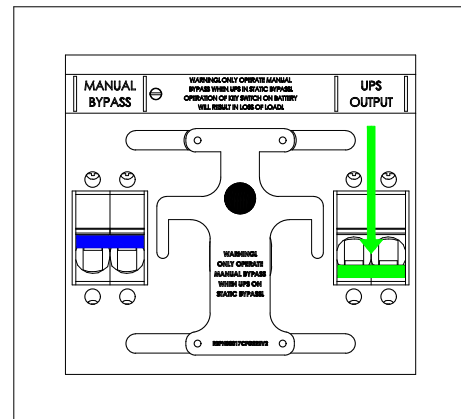

MANUAL BYPASS:
-IN THE ON POSITION

INTERLOCK KEY :
-REMOVED

UPS OUTPUT:
-IN THE OFF POSITION

UPS UNIT:
-STATIC BYPASS - LOAD ON MAINS

STEP H

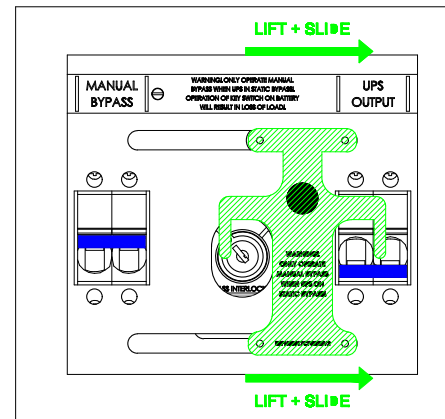

MANUAL BYPASS:
-IN THE ON POSITION

INTERLOCK KEY :
-REMOVED

UPS OUTPUT:
-IN THE OFF POSITION

UPS UNIT:
-STATIC BYPASS - LOAD ON MAINS

STEP I

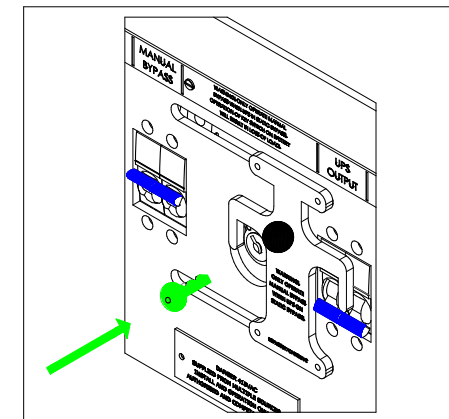

MANUAL BYPASS:
-IN THE ON POSITION

INTERLOCK KEY :
-INSERTED + TURNED ANTI-CLOCKWISE

UPS OUTPUT:
-IN THE OFF POSITION

UPS UNIT:
-STATIC BYPASS - LOAD ON MAINS

STEP J

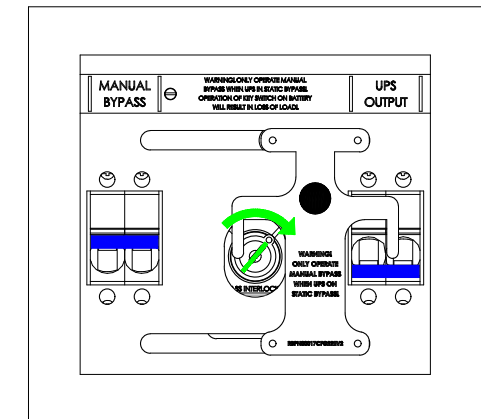

MANUAL BYPASS:
-IN THE ON POSITION

INTERLOCK KEY :
-INSERTED + TURNED CLOCKWISE

UPS OUTPUT:
-IN THE OFF POSITION

UPS UNIT:
-STATIC BYPASS - LOAD ON MAINS

NOTES:

- 1) PRODUCT MUST BE INSTALLED IN COMPLIANCE WITH ALL NATIONAL AND LOCAL ELECTRICAL REGULATIONS
- 2) PLEASE REFER TO UPS PRODUCT MANUALS FOR ADDITIONAL INFORMATION
- 3) ALL DIMENSIONS IN MM UNLESS OTHERWISE SPECIFIED
- 4) 4 - CORE SHIELDED SIGNAL CABLE MUST BE RUN FROM EMBS TO EACH UPS UNIT
- 5) ALL DASHED LINES EXTERNAL TO BYPASS PANEL

PRODUCT REF:

RB1-C-EMBS-80A-2P-ISO

DOCUMENT NUMBER:

RBECAD-00079

PAGE DESCRIPTION:

INTERLOCK OPERATION PAGE 1

PROJECT NO:

SUBMITTAL DRAWING

PAGE TEMPLATE REF:

RBQS00078REV2

PRODUCT WEIGHT:

15KG

REV NO:

1

CREATION DATE:

29/04/2016

REV DATE:

25/05/2016

DRAWN BY:

R BARNES

CHECKED BY:

M BRADLEY

SHEET NUMBER:

3 OF 5

DO NOT USE THIS PROCEDURE IF THE MAINS IS NOT AVAILABLE. IF IN ANY DOUBT CONTACT YOUR UPS SERVICE PROVIDER.

STEP K (ON BYPASS POSITION)

THIS PROCEDURE ASSUMES:

ALL SWITCHES ON THE EMBS AND ON THE UPS UNIT SHOULD STILL BE AS PER STEP J ON THE PREVIOUS PAGE PRIOR TO PROCEEDING

THE UPS UNIT SHOULD BE IN STATIC BYPASS AND SHOULD BE READY TO ACCEPT THE SYSTEM LOAD

IF IN ANY DOUBT CONTACT YOUR UPS SYSTEM SERVICE PROVIDER BEFORE PROCEEDING

MANUAL BYPASS:
-IN THE ON POSITION

INTERLOCK KEY :
-INSERTED + TURNED CLOCKWISE

UPS OUTPUT:
-IN THE OFF POSITION

UPS UNIT:
-STATIC BYPASS - LOAD ON MAINS

STEP L

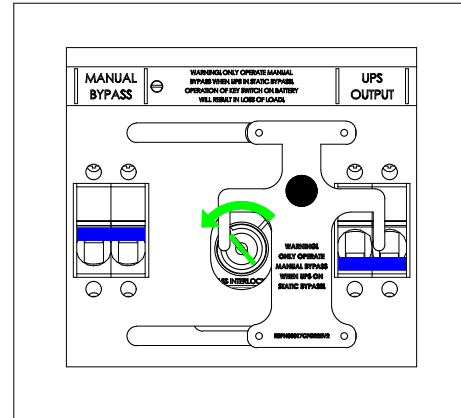

MANUAL BYPASS:
-IN THE ON POSITION

INTERLOCK KEY :
-INSERTED + TURNED ANTI-CLOCKWISE

UPS OUTPUT:
-IN THE OFF POSITION

UPS UNIT:
-STATIC BYPASS - LOAD ON MAINS

STEP M

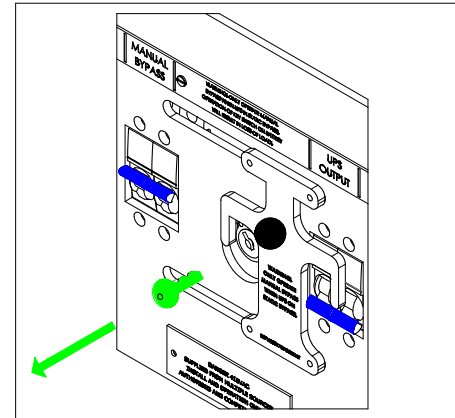

MANUAL BYPASS:
-IN THE ON POSITION

INTERLOCK KEY :
-REMOVED

UPS OUTPUT:
-IN THE OFF POSITION

UPS UNIT:
-STATIC BYPASS - LOAD ON MAINS

STEP N

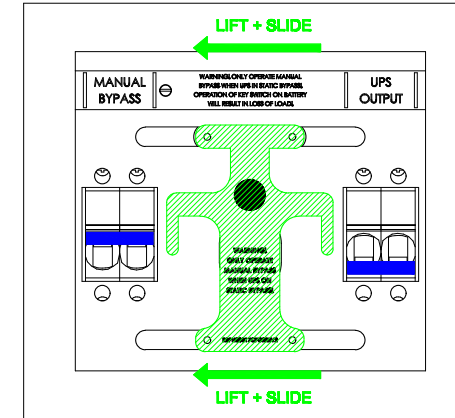

MANUAL BYPASS:
-IN THE ON POSITION

INTERLOCK KEY :
-REMOVED

UPS OUTPUT:
-IN THE OFF POSITION

UPS UNIT:
-STATIC BYPASS - LOAD ON MAINS

STEP O

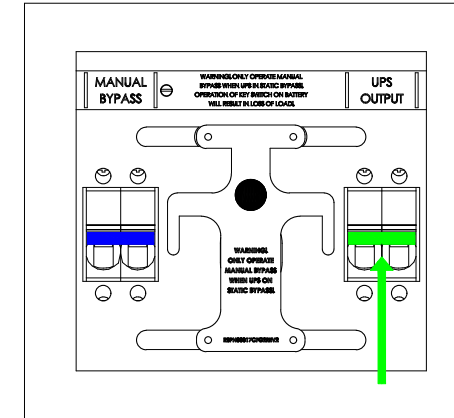

MANUAL BYPASS:
-IN THE ON POSITION

INTERLOCK KEY :
-REMOVED

UPS OUTPUT:
-IN THE ON POSITION

UPS UNIT:
-STATIC BYPASS - LOAD ON MAINS

STEP P

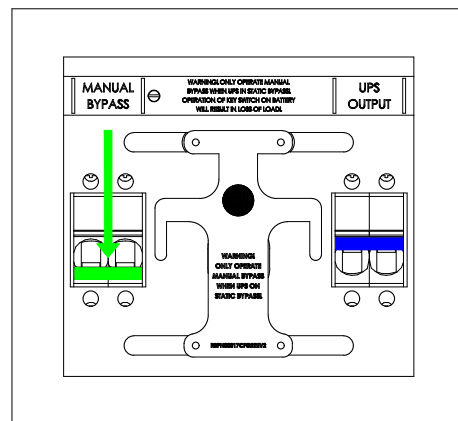

MANUAL BYPASS:
-IN THE OFF POSITION

INTERLOCK KEY :
-REMOVED

UPS OUTPUT:
-IN THE ON POSITION

UPS UNIT:
-STATIC BYPASS - LOAD ON MAINS

STEP Q

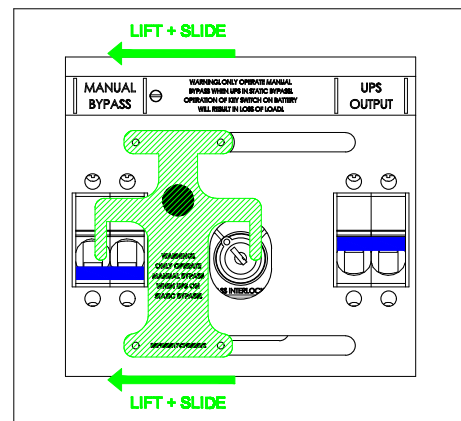

MANUAL BYPASS:
-IN THE OFF POSITION

INTERLOCK KEY :
-REMOVED

UPS OUTPUT:
-IN THE ON POSITION

UPS UNIT:
-STATIC BYPASS - LOAD ON MAINS

STEP R

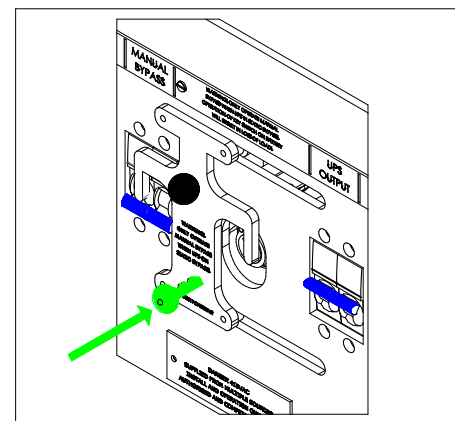

MANUAL BYPASS:
-IN THE OFF POSITION

INTERLOCK KEY :
-INSERTED + TURNED ANTI-CLOCKWISE

UPS OUTPUT:
-IN THE ON POSITION

UPS UNIT:
-STATIC BYPASS - LOAD ON MAINS

STEP S

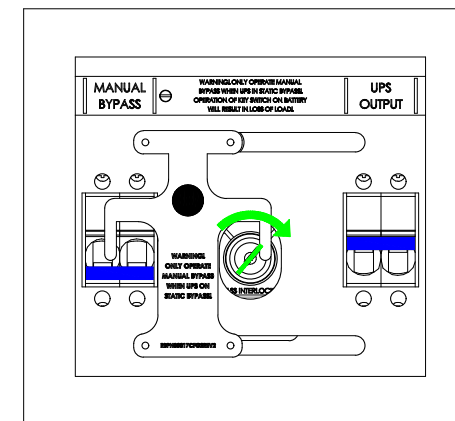

MANUAL BYPASS:
-IN THE ON POSITION

INTERLOCK KEY :
-INSERTED + TURNED CLOCKWISE

UPS OUTPUT:
-IN THE OFF POSITION

UPS UNIT:
-STATIC BYPASS - LOAD ON MAINS

STEP T

REFER TO UPS USER MANUAL TO SWITCH THE UPS UNIT (OR UNITS) TO ONLINE MODE

ONCE UPS UNIT (OR UNITS) ARE ONLINE THE SEQUENCE IS COMPLETE AND THE LOAD IS NOW BACKED UP BY UPS

IF IN ANY DOUBT CONTACT YOUR UPS SERVICE PROVIDER

MANUAL BYPASS:
-IN THE OFF POSITION

INTERLOCK KEY :
-INSERTED + TURNED CLOCKWISE

UPS OUTPUT:
-IN THE ON POSITION

UPS UNIT:
-ONLINE - LOAD ON UPS

NOTES:

- 1) PRODUCT MUST BE INSTALLED IN COMPLIANCE WITH ALL NATIONAL AND LOCAL ELECTRICAL REGULATIONS
- 2) PLEASE REFER TO UPS PRODUCT MANUALS FOR ADDITIONAL INFORMATION
- 3) ALL DIMENSIONS IN MM UNLESS OTHERWISE SPECIFIED
- 4) 4 - CORE SHIELDED SIGNAL CABLE MUST BE RUN FROM EMBS TO EACH UPS UNIT
- 5) ALL DASHED LINES EXTERNAL TO BYPASS PANEL

PRODUCT REF:

RB1-C-EMBS-80A-2P-ISO

DOCUMENT NUMBER:

RBECAD-00079

PAGE DESCRIPTION:

INTERLOCK OPERATION PAGE 2

PROJECT NO:

SUBMITTAL DRAWING

PAGE TEMPLATE REF:

RBQS00078REV2

PRODUCT WEIGHT:

15KG

REV NO:

1

CREATION DATE:

29/04/2016

REV DATE:

25/05/2016

DRAWN BY:

R BARNES

CHECKED BY:

M BRADLEY

SHEET NUMBER:

4 OF 5

MECHANICAL LAYOUT

TOP VIEW:

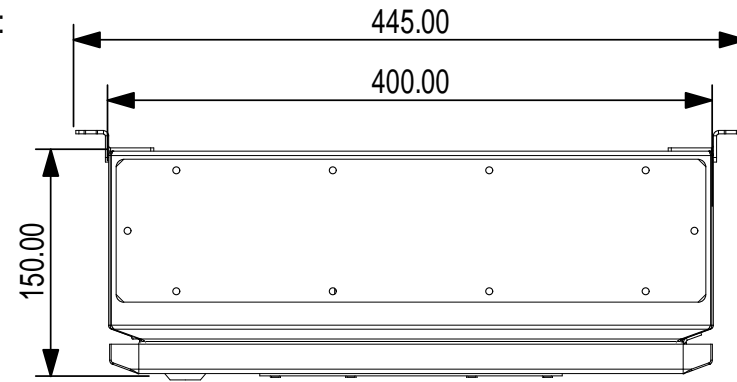

TERMINATION DETAILS:

CABLING GLANDING: TOP/BOTTOM

CABLE TERMINATION:

MAINS INPUT: TERMINAL (TOP)

LOAD OUTPUT: TERMINAL (BOTTOM)

UPS IN: DIRECT TO DEVICE (BOTTOM)

UPS OUT: DIRECT TO DEVICE (TOP)

FRONT VIEW:

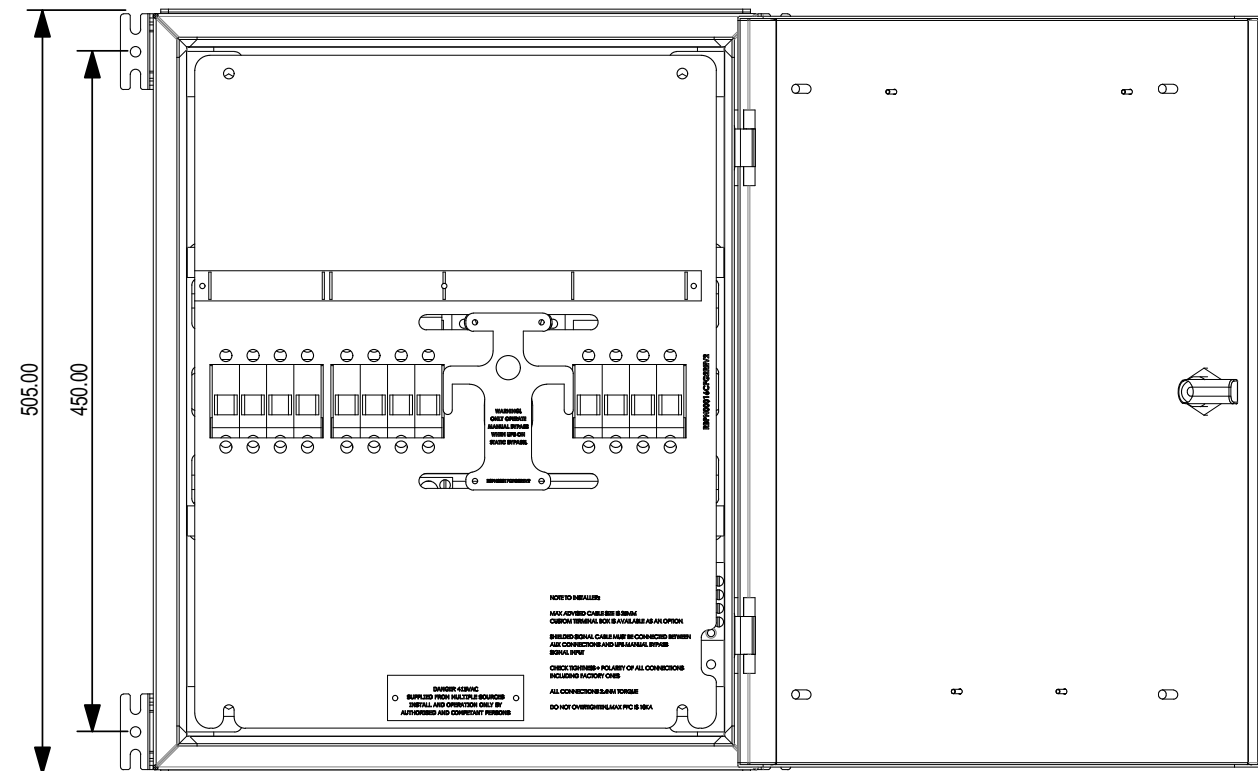

RIGHT VIEW:

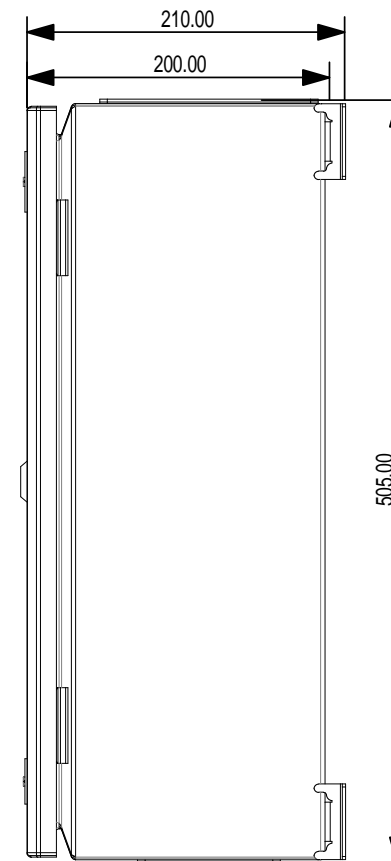

ISO VIEW:

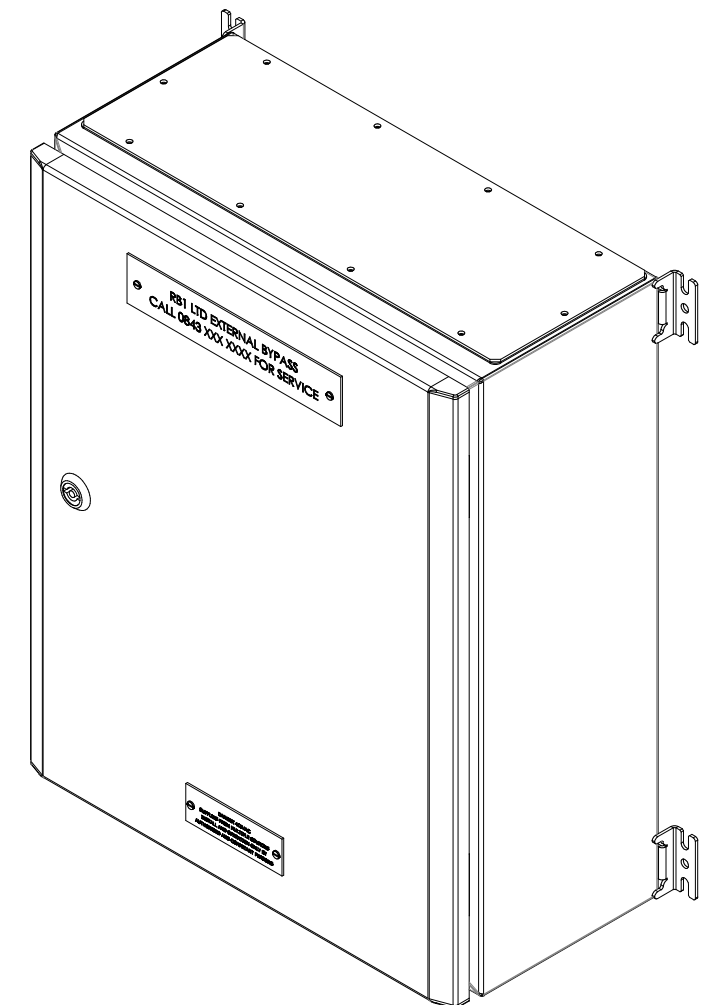

NOTES:

- 1) PRODUCT MUST BE INSTALLED IN COMPLIANCE WITH ALL NATIONAL AND LOCAL ELECTRICAL REGULATIONS
- 2) PLEASE REFER TO UPS PRODUCT MANUALS FOR ADDITIONAL INFORMATION
- 3) ALL DIMENSIONS IN MM UNLESS OTHERWISE SPECIFIED
- 4) 4 - CORE SHIELDED SIGNAL CABLE MUST BE RUN FROM EMBS TO EACH UPS UNIT
- 5) ALL DASHED LINES EXTERNAL TO BYPASS PANEL

PRODUCT REF:	RB1-C-EMBS-80A-2P-ISO	REV NO:	1
DOCUMENT NUMBER:	RBECAD-00079	CREATION DATE:	29/04/2016
PAGE DESCRIPTION:	MECHANICAL LAYOUT	REV DATE:	25/05/2016
PROJECT NO:	SUBMITTAL DRAWING	DRAWN BY:	R BARNES
PAGE TEMPLATE REF:	RBQS00078REV2	CHECKED BY:	M BRADLEY
PRODUCT WEIGHT:	15KG	SHEET NUMBER:	5 OF 5